

RF Receivers

Detailed information

www.rfxcom.com

1. Table of Contents

1.	Table of Contents.....	2
2.	IMPORTANT NOTES.....	3
3.	Available receivers.....	3
3.1.	310MHz X10 only	3
3.2.	433.92MHz receiver.....	3
4.	Receiver installation in an USB module.....	3
5.	Receiver installation in an Ethernet module.....	3
6.	Connecting the USB interface to your system.....	4
7.	Configuring the Ethernet interface.....	4
8.	The RS232 data format used.....	4
9.	Hex Initialization commands.....	4
9.1.	310MHz X10 only receiver.....	4
9.2.	433.92MHz receiver.....	4
10.	Variable length mode packet.....	5
11.	How received RF data is handled.....	5
12.	Example of received data packets for an A1-off cmd	6
13.	KlikOn-KlikOff chime command.....	6
14.	Handshake signal.....	7
15.	DIY options.....	8
15.1.	Receiver PCB	8
15.2.	Antenna.....	8
15.3.	Pushbutton.....	8
15.4.	Relay.....	8
15.5.	Signal strength testing.....	8
15.6.	Create your own program for the microcontroller.....	9
16.	Schematics and connections.....	9
16.1.	Receiver schematics	9
16.2.	Bus and microcontroller connections.....	9
17.	Q&A.....	10
18.	Warning:.....	10
19.	Copyright notice.....	10
20.	Revision history.....	11

2. IMPORTANT NOTES.

- An X10 receiver needs to have version 9 or higher when installed together with a Visonic receiver in an USB/Ethernet interface!
- The RFXCOM Homeseer plug-in needs receivers with firmware version 21 or higher.
- A handshake cable must be connected to the receiver USB and an operational transmitter if the USB interface of the receiver has a jack input for a handshake cable. Or make a connection between the top and middle pin of the jack connector.

3. Available receivers.

3.1. 310MHz X10 only

1. 310MHz Master Receiver for X10 RF, X10 security, NEC codes
2. 310MHz Slave Receiver for X10 RF, X10 security, NEC codes

3.2. 433.92MHz receiver

1. 433.92MHz Master Receiver for X10 RF, X10 security, Oregon Scientific, ARC-Tech, ATI Remote Wonder, NEC codes
2. 433.92MHz Slave Receiver for X10 RF, X10 security, Oregon Scientific, ARC-Tech, ATI Remote Wonder, NEC codes

These receivers are able to receive and decode the given RF commands. The packets are then transmitted in RS232 format to the USB/Ethernet module. ARC-Tech is used in KlikOn-KlikOff, ELRO AB600, NEXA and Domia lite.

4. Receiver installation in an USB module.

Disconnect the USB module completely to be sure it is powerless.

The Master receiver should be plugged in into the J1 connector of the USB module.

An optional Slave receiver must always be plugged in into the J2 connector.

An USB module can only have mounted:

- 1 Master receiver **OR** 1 Master receiver and 1 Slave receiver

OR

- 1 Transmitter. (4800bd only)

5. Receiver installation in an Ethernet module.

Disconnect the power from the Ethernet module.

The Master receiver should be plugged in into the JP4 connector of the Ethernet module.

An optional Slave receiver must always be plugged into the JP5 connector.

An Ethernet module with 1 COM port can only have mounted:

- 1 Master receiver **OR** 1 Master receiver and 1 Slave receiver

OR

- 1 Transmitter in JP4. (4800bd only)

An Ethernet module with 2 COM ports can have mounted:

- 1 Master receiver **OR** 1 Master receiver and 1 Slave receiver

AND

- 1 Transmitter in JP6. (4800bd only)

6. Connecting the USB interface to your system.

Install the USB driver.

Connect the USB module to an USB port.

7. Configuring the Ethernet interface.

For a detailed description of the configuring of the Ethernet Interface see the RFXCOM Ethernet Interface document.

8. The RS232 data format used.

- 4800bd, 8 bits data, no parity, 1 stop bit.
- 38400 bd, 8 bits data, no parity, 1 stop bit.

9. Hex Initialization commands.

9.1. *310MHz X10 only receiver*

- F020 = return software version
- F021 = RFXCOM HS plug-in mode
- F025 = toggle baud rate
- F029 = receive X10, security and Oregon temp, output is 32 bits
- F02A = enable all possible receiving modes
- F02C = variable length mode receiving.
- F02F = disable receiving of X10 and security RF in modes 21, 29 and 2C
- F040 = disable this X10 receiver. Other receiver is in Visonic mode.
- F041 = receive variable length mode receiving. Other receiver is in Visonic mode.

9.2. *433.92MHz receiver*

- F020 = return software version
- F021 = RFXCOM HS plug-in mode
- F024 = receive ARC-Tech codes
- F025 = toggle baud rate
- F028 = disable receiving of HomeEasy RF
- F029 = receive X10, security, ARC-Tech output is 32 bits
- F02A = enable all possible receiving modes
- F02C = variable length mode receiving.
- F02D = disable receiving of ARC-Tech RF in modes 21, 29 to 2C
- F02E = disable receiving of Ikea-Koppla RF (special receiver)
- F02F = disable receiving of X10 and security RF in modes 21, 29 to 2C
- F040 = disable this X10 receiver. Other receiver is in Visonic mode.
- F041 = variable length mode receiving. The other receiver is in Visonic mode.
- F042 = used in Visonic receiver to clear auxiliary contacts
- F043 = disable receiving of Oregon RF
- F044 = disable receiving of ATI Remote Wonder RF
- F045 = disable Visonic receiving

10. Variable length mode packet

The first byte of the packet in variable length mode doesn't belong to the RF data received. The bits 6-0 of the first byte contain the packet length in hex of the RF data received.

Important: The most significant bit 7 of the first byte indicates if the packet is received by the Master receiver (bit7=0) or by the Slave receiver (bit7=1)

11. How received RF data is handled.

- On reception of an initialize command the receiver will respond with a byte equal to the second byte. E.g. if a hex init command "F029" is received, the receiver responds with "29". On disable RF commands the receiver will respond with the mode set.
- Only valid RF and X10 packets are sent to the RS232 port in "F029" 32 bits mode. This mode is also compatible with the W800RF32 receiver.
- In ARC mode only ARC-Tech RF packets are received and transmitted in variable length packets with ARC-Tech native format to the RS232 interface.
- In the modes 21, 29 and 2C the received ARC-Tech RF packets are converted to X10 format.
- In the mode 21 and 29 only the temperature field from the received Oregon packets is translated to RFXSensor format.
- The ATI Remote Wonder commands are sent to the RS232 in native format. In mode 29 there are 12 bits added to the packet to have 32 bits.

Note: a disabled receiver doesn't respond on a software version request and doesn't respond with an ACK to the set disable command.

12. Example of received data packets for an A1-off cmd

(all data is in hex format)

Version request to receiver => F020

4D185330 version of Master & optional Slave receiver.
Master = version 18, Slave = version 30

Init cmd to receiver => F024 (433.92MHz receiver only)

24 ACK received
140004 Housecode=C Group= 1 Unit= 1 Command: OFF received

Init cmd to receiver => F029

29 ACK received
609F20DF A1-Off received

Init cmd to receiver => F02A

2A ACK received
609F20DF A1-Off received

Init cmd to receiver => F02C

2C ACK received
20609F20DF A1-Off received by a Master receiver
20H=32 decimal bits received
A0609F20DF A1-Off received by a Slave receiver
Bit7 on=slave receiver + 20H=32 decimal bits received

Disable KAKU RF => F02D (433.92MHz receiver only)

2C ACK received (ACK=current mode F02C)

Disable X10 RF => F02F (433.92MHz receiver only)

2C ACK received (ACK=current mode)

13. KlikOn-KlikOff chime command.

If in X10 mode a KlikOn-KlikOff chime command is received it will be translated to an X10 unit number 8.

14. Handshake signal.

The Master receiver has a Transmit Request input and a Clear to Send output connection. Those signals are used by a transmitter that operates on the same frequency as the Master receiver. Before starting the transmission, the transmitter sends a Transmit Request to the Master receiver. If the Master receiver has not received a signal for about 60ms it responds with a Clear to Send to the transmitter and stops receiving until the Transmit Request is switched off by the transmitter. On the Clear to Send signal the transmitter starts transmitting.

See the Handshake document how to connect the handshake cable between 2 RFXCOM interfaces.

Important note:

- A receiver in a small size (9x6x3cm) USB interface that has the jack input installed for the handshake cable needs to have the handshake cable connected to an operational transmitter. Or make a connection between the top and middle pin of the jack connector.

15. DIY options.

15.1. Receiver PCB

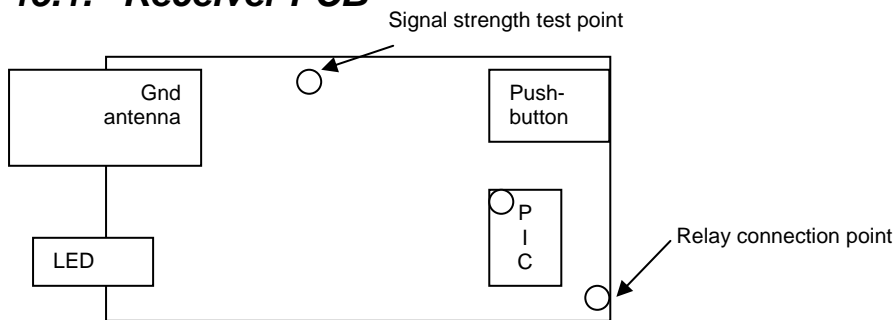

15.2. Antenna.

The wire antenna can be replaced by a standard antenna. The cable to be used must be a 50ohm coax with an F-connector at the receiver side. The F-connector has an impedance of 75ohm while the receiver uses 50ohm. The loss in the F-connector is very low and because it is easy to mount an F-connector this type of connector has been chosen. The available groundplane antennas will more than double the receiver range. Also a 70cm HAM radio antenna can be used with the 433.92MHz receiver. A disccone antenna can be used with the 310MHz receiver.

15.3. Pushbutton.

(The pushbutton switch and the 1k series resistor are not installed on the receiver)
When the pushbutton input is low, the device address of any received X10 command is saved in EEPROM. When a command with this address is received the Relay output is switched On or Off depending if an On or Off command is received.

15.4. Relay.

The PCB has a relay connection point which can be used for a relay driver circuit. The maximum output current sunk and sourced is 25mA and 5 volt.

15.5. Signal strength testing.

The PCB has a connection point for measurement of the received signal strength. Connect an oscilloscope to this point and set the channel to 0.5 Volt/Div and 1ms/Div. The received signal is about 2V peak when a signal from a device on short distance is received.

15.6. Create your own program for the microcontroller.

The microcontroller used on the receiver PCB is a Microchip 16F688. This microcontroller can be programmed with a Microchip PICKit 1 Flash starter kit. The 14-pins connector used on the receiver PCB is **NOT** compatible with the 14-pins connector of the PICKit 1 programmer. To connect the receiver PCB to the programmer, create an adapter:

Receiver	Programmer	Signal
Pin 3	pin 3	Vpp
Pin 4	pin 8	Pclk
Pin 7	pin 7	Pdata
Pin13	pin 13	+5V
Pin 14	pin 14	GND

For more information about PICKit 1 see:

http://www.microchip.com/stellent/idcplg?IdcService=SS_GET_PAGE&nodeId=1406&dDocName=en010053

16. Schematics and connections.

16.1. Receiver schematics

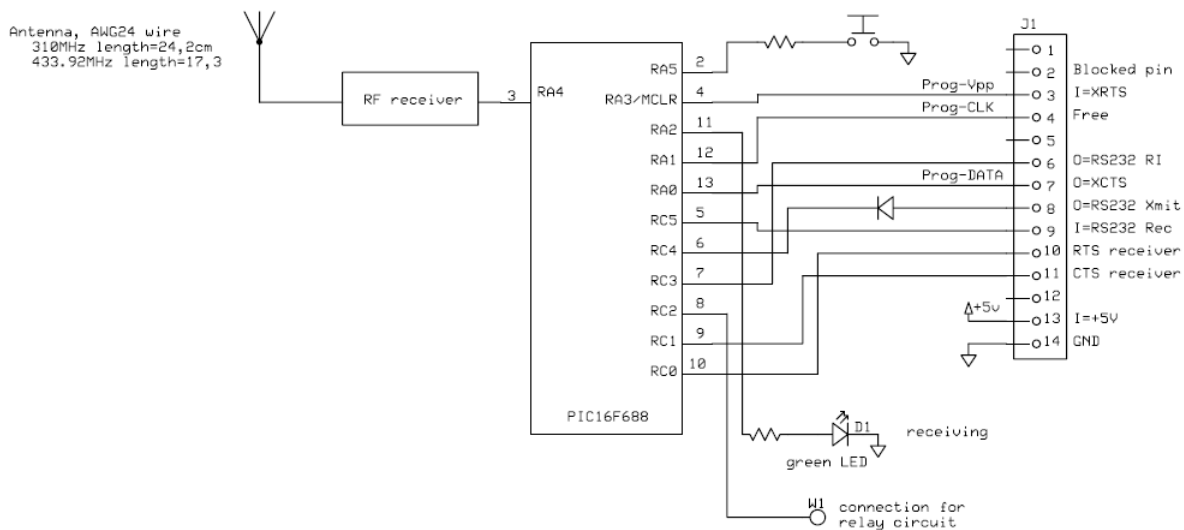

16.2. Bus and microcontroller connections.

pin	USB RS232	prog	16F688	Master receiver	Slave receiver
1			RA5-2	(I=pushbutton)	(I=pushbutton)
2			RA4-3	(RF rec data)	(RF rec data)
3		Vpp	RA3-4	I=XRTS	Not used
4		CLK	RA1-12	free	free
5			RA2-11	(LED)	(LED)
6	I=RS232 RI		RC3-7	O=RS232 RI	free
7		DATA	RA0-13	O=XCTS	Not used
8	I=RS232 RD		RC4-6	O=RS232 Tx	O=RS232 Tx
9	O=RS232 TD		RC5-5	I=RS232 Rx	I=RS232 Rx
10			RC0-10	I=RTS receiver	O=RTS receiver
11			RC1-9	O=CTS receiver	I=CTS receiver
12			RC2-8	(O=Relay)	(O=Relay)
13	+5V	VDD	VDD-1	VDD	VDD
14	GND	GND	GND-14	GND	GND

Note:(Signal is used by the microcontroller but not connected to the 14-pins connector)

17. Q&A

Q The receiver does not receive anything and doesn't respond to an initialize command. (or will operate sometimes)

A There is no handshake cable connected to the USB interface.

Q The receiver receives only 1 byte packets or long packets of non valid data and doesn't respond to an initialize command.

A The receiver is using a different baudrate as the software.

Use the RFreceiver program to switch the baud rate in the receiver:

- o Connect the receiver and select the baud rate that is different from the baud rate used by the software,
- o Click the "Toggle Baud Rate (don't use)" button.

Q Using the groundplane antenna, the receiver receives a lot of non valid data but receives also valid data. Using the wire antenna most of the received data is valid data.

A There is something transmitting on a distance at the same frequency as the receiving frequency.

Q Only non valid data is received. With no difference when using the groundplane antenna or the wire antenna.

A There is a transmitter active close to your location and transmitting at the same frequency as the receiving frequency.

18. Warning:

RF signals are possible disturbed and it has not been justified for this equipment at uses in circumstances where life-threatening or dangerous situations are possible.

19. Copyright notice

All materials contained in this document are protected by copyright laws, and may not be reproduced, republished, distributed, transmitted, displayed, broadcast or otherwise exploited in any manner without the express prior written permission of RFXCOM.

20. Revision history.

Version 15.0 – September 26, 2007

Version 15.1 – October 14, 2007

Chapter 11. Version request response string changed.

Version 16.0 – November 4, 2007

F02E is only used to disable Ikea-Koppla in the special Koppla receiver.

Version 17.0 – January 22, 2008

RAW receiving modes deleted.

RFXCOM Homeseer plug-in support added.

ARC mode changed to variable length.

Version 18.0 – January 23, 2008

Disable Visonic receiving added

Version 19.0 – Februari 18, 2008

Disable HomeEasy added.

Version 19.1 – April 1, 2008

Text “hex” added at commands.

Version 19.2 – April 25, 2008

Handshake information moved to handshake document.